

# INSTALLATION INSTRUCTIONS

CTS602 HMI BY NILAN



## Compact P2 / Compact P2 Polar Gateway

Version 1.30 - 01.05.2024  
M24 Compact P2 GB

 **NILAN**<sup>®</sup>  
OUTSTANDING INDOOR CLIMATE

# Table of contents

## General information

Important information .....	4
Safety .....	4
Power supply .....	4
Heat pump domestic hot water .....	4
Water quality requirements .....	4
Requirements to quality of water .....	4
Introduction .....	5
Documentation .....	5
Unit type .....	6
Product description .....	6
The unit .....	7
Temperature sensor overview .....	8
Dimensional drawing .....	8
Accessories .....	9
Electrical pre-heating element for frost protection of the unit .....	9
Electrical after-heating element for duct installation .....	9
CO2 sensor .....	9
Expansion PCB .....	9
EM-box .....	9
DTBU damper .....	10
Extension cable HMI control panel .....	10
Cover plate HMI user panel .....	10
Safety group .....	10
Safety group with scalding protection .....	10
Flexible sound damper .....	11
Pollen filter .....	11
Trolley .....	11

## Set-up

Mounting .....	12
Transport into the building .....	12
Positioning the unit .....	12

## Electrical installation

Safety .....	13
Connections overview .....	13
Electrical connection unit .....	13
Power supply .....	13
Connecting a gateway .....	14
Connecting to the internet .....	14
Location on the unit .....	14
HMI Control panel .....	15
Moving the control panel .....	15
Wall bracket .....	15
Electrical connection accessories .....	16
User selection 1 .....	16
Smart Grid .....	17
External electrical pre-heating element .....	18
Electrical after-heating element .....	19
Electrical after-heating element for mounting on top or on the side .....	20
Mounting an expansion PCB on the CTS602 circuit board .....	21
User selection 2 .....	23
Connection EHD damper .....	24
BAH Geothermal heating element .....	25
EM-box (damper option) .....	26
DTBU (damper option) .....	27
Fire thermostat / external fire automation system .....	27
Joint alarm .....	28
External heat supply .....	28

## Plumbing installation

Condensate drain .....	29
Important information .....	29
Hot water tank .....	30
Connection overview .....	30
Plumbing connection .....	30
Requirements to quality of water .....	31
Hot water circulation .....	31

Supplementary coil .....	31
Softened water .....	31
Plumbing connections accessories .....	32
Safety group .....	32
Safety group with anti-scald protection .....	32

## Ventilation installation

Duct system .....	33
Legislation .....	33
Ducts .....	33
Ventilation unit .....	33
Extract air .....	34
Supply air .....	34
Roof terminals .....	34
Installation example .....	34
Balancing .....	35
Important information .....	35

## Troubleshooting

Emergency mode .....	36
Emergency mode domestic hot water .....	36
Domestic hot water .....	37
Errors and solutions domestic hot water .....	37

# General information

## Important information



### CAUTION

Do not turn on the power supply for the unit until the hot-water tank and central heating circuit is filled with water.

## Safety

### Power supply



### CAUTION

Always disconnect the power supply to the unit if an error occurs that cannot be rectified via the control panel.



### CAUTION

If an error occurs on electrically conductive parts of the unit, always contact an authorised electrician to rectify the error.



### CAUTION

Always disconnect the power to supply to the unit before opening the unit doors, for instance for installation, inspection, cleaning and filter change.

## Heat pump domestic hot water



### CAUTION

Avoid direct contact with the heating system pipes in the heat pump as they can get very hot.



### CAUTION

To protect the heat pump against damage, it is equipped with electronic temperature monitoring.

The heat pump must undergo suitable service inspections under applicable legislation and regulations to keep it in good condition and in compliance with safety and environmental requirements.

Responsibility for maintenance of the heat pump rests with the owner/user.

## Water quality requirements

### Requirements to quality of water

The hot water tank in the Nilan units is made of steel, which has been given a double enamelling, to ensure an extra long service life. In addition, the tank is equipped with a sacrificial anode as extra protection. It is important that the sacrificial anode is replaced regularly.

Most units are equipped with an electronic monitoring sacrificial anode, which gives an alarm on the user panel when it is time to replace it.

In order for the sacrificial anode to function and protect the tank, it is required that the water quality complies with the following:

- Electrical conductivity (EC): Between 30 mS/m and 150 mS/m (millisiemens pr. m)  $\leq$  25 °C
- Chloride must be below 250 mg/L  $\leq$  65 °C

If the above criteria are not met, the sacrificial anode will not work as intended, after which the tank will be corroded.

# Introduction

## Documentation

The following documents will be supplied with the unit:

- Quick guide
- Wiring diagram

In the Quick guide you will find important information regarding installation and start-up of the unit. If you require further information regarding, for instance, installation of accessories or additional settings in the software, or if you need an extended user manual, the following documents can be downloaded from the Nilan website:

- Installation instructions
- Software instructions
- User Manual
- Wiring diagram

The instructions can be downloaded from [www.nilan.dk](http://www.nilan.dk).

If you have questions regarding installation and operation of the unit after having read the instructions, please contact your nearest Nilan dealer. A list of Nilan dealers is available on [www.nilan.dk](http://www.nilan.dk).



### ATTENTION

The unit must be started up immediately after installation and connection to the duct system.

When the ventilation unit is not in operation, humidity from the rooms will enter the duct system and create condensate water that can run out of the valves and cause damage to floors and furniture. Condensation may also form in the ventilation unit, which can damage its electronics and fans.

From factory, the unit has been tested and is ready for operation.

# Unit type

## Product description

Compact P2 is a ventilation unit with heat recovery, that has a built-in heat pump, which is used for the production of domestic hot water, but which is able to heat and cool the home via the ventilation air.

Compact P2 is designed for air flows of up to 425 m<sup>3</sup>/h at 75 Pa external counter-pressure.

The unit is primarily used in residential construction such as single-family houses and apartments. It ventilates the home by drawing out the moist and bad air via valves in e.g. bathrooms, toilet, kitchen and utility room, and introduces fresh outdoor air in via valves in living rooms such as. living room, bedrooms and family room.

The cold outdoor air is heated via the high-efficiency counterflow heat exchanger by the hot exhaust air. The heat loss that occurs via heat recovery, the built-in heat pump use to produce domestic hot water. All the energy in the exhaust air is utilized, and you have not really seen any heat loss that you experience with an ordinary ventilation unit.

In the winter, the built-in heat pump can heat the supply air up to 34 °C, and thus contribute to heating the home. When the supply air is heated, at the same time a little heat is deposited in the hot water tank and ensures a constant high hot water temperature.

The heat pump has a reversible cooling circuit, which means that the cooling circuit can be turned and it can cool the supply air in the summer. Compact P2 can cool the supply air by up to 10 °C in relation to the outdoor air. Due to the low air exchange, usually 1/2 time per hour, it will not act as an air conditioning system. However, when cooling, moisture in the supply air is removed, which results in a lower humidity in the home. The lower humidity means that it is easier to withstand a slightly higher temperature, which therefore provides good comfort in the home.

When Compact P2 cools the supply air, the energy is deposited in the hot water tank, and it can thus be said that "free" domestic hot water is produced during those periods.

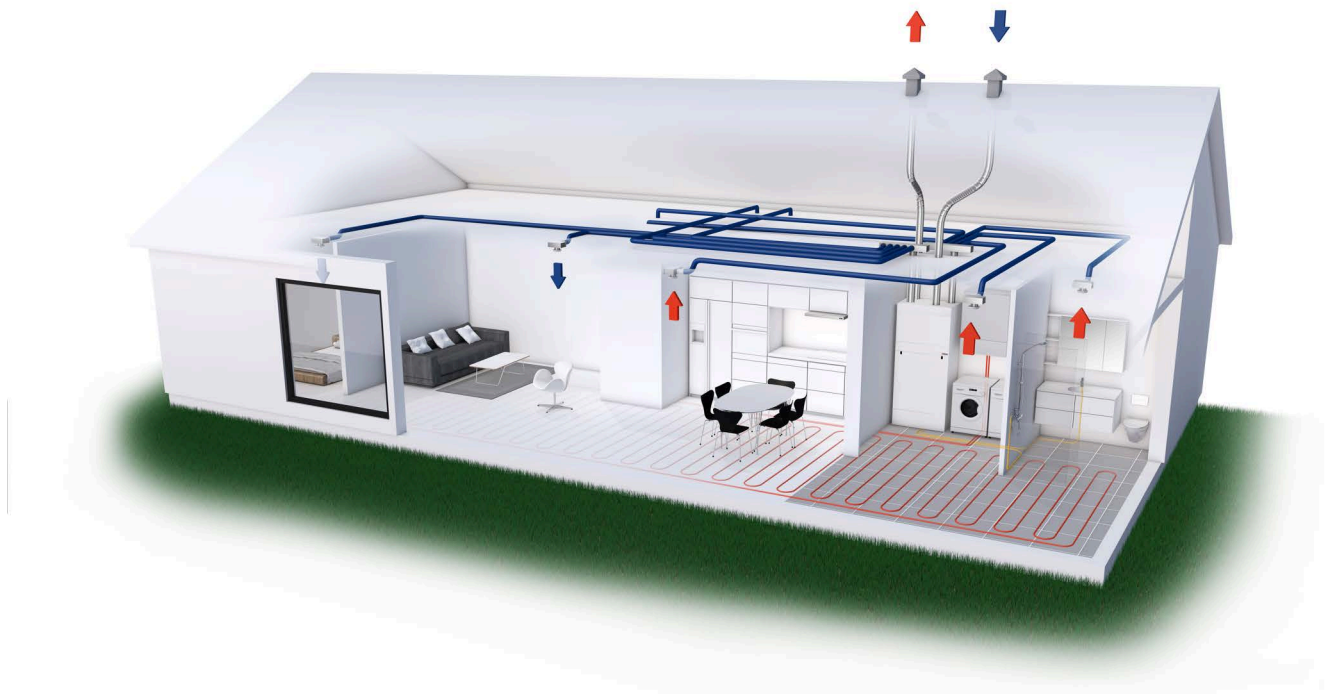

## The unit

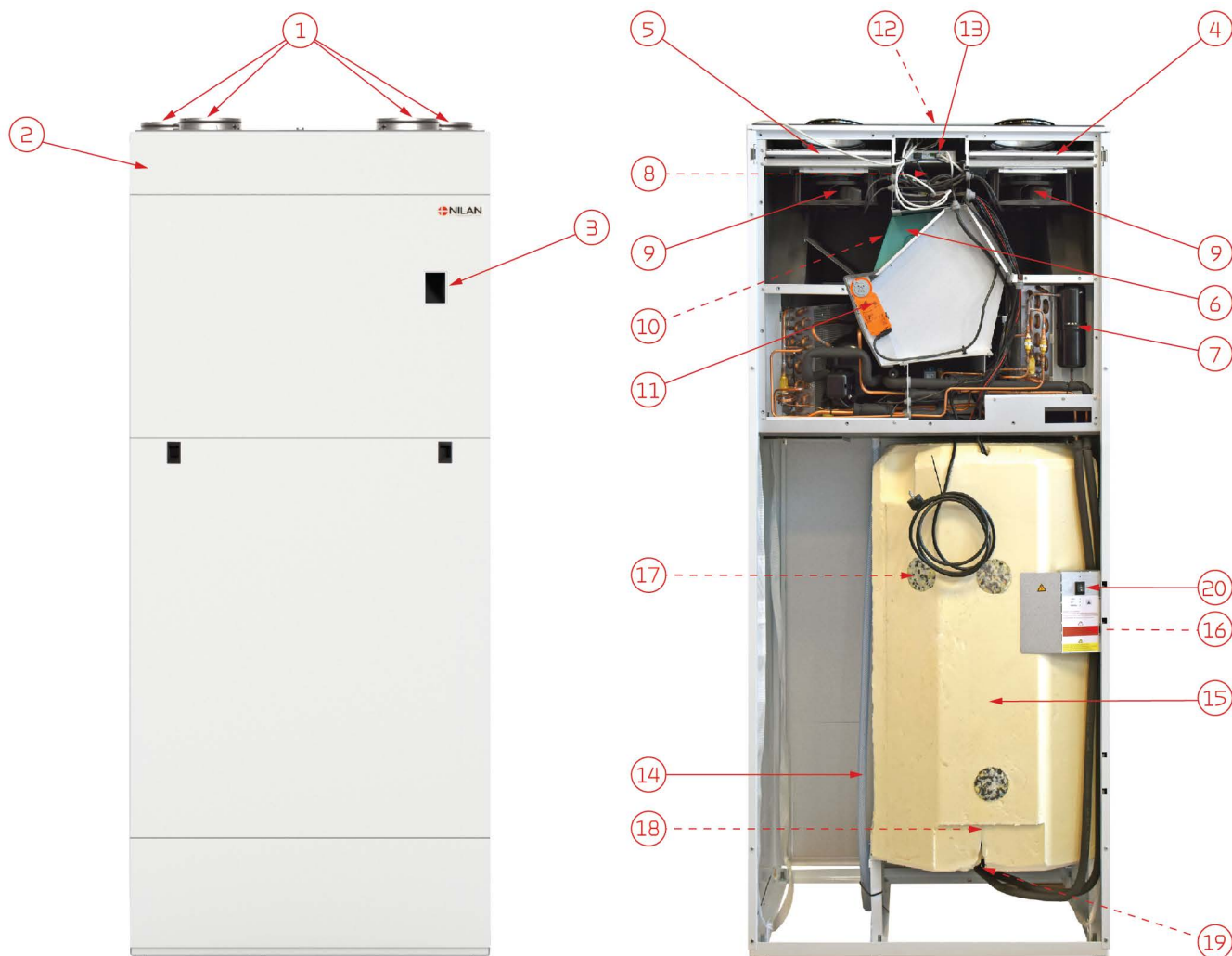

1. Duct connections
2. Filter change cover
3. Control panel (HMI touch-panel)
4. Extract air filter
5. Outdoor air filter (pollen filter is placed here if required)
6. Counterflow heat exchanger
7. Heat pump
8. Automation CTS602
9. Fans
10. Pre-heating element for frost protection (Polar version only)

11. 100% bypass damper
12. Electrical connections accessories
13. Gateway for App option
14. Condensate drain with water trap
15. 180 l hot water tank
16. 1,5 kW electrical supplement heater (with overheat protection)
17. Electronically monitored sacrificial anode
18. Supplementary coil (only SOL version)
19. Plumbing connections
20. Emergency mode (domestic hot water)

## Temperature sensor overview

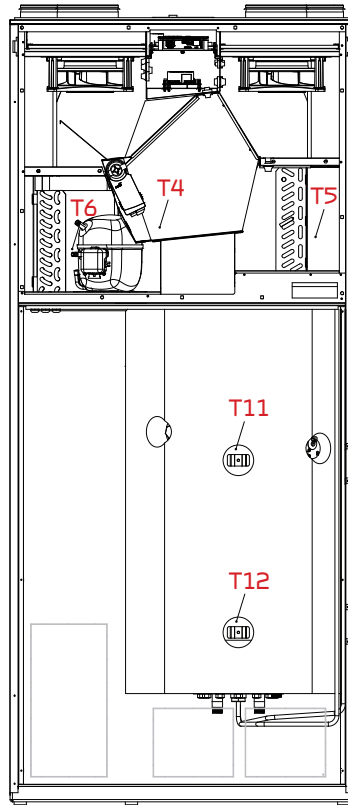
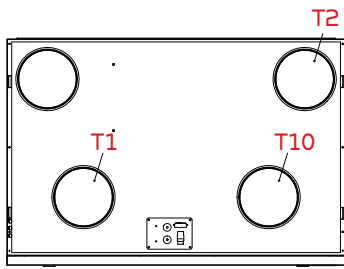

### Temperature sensors inside the unit

- T1: Outdoor air
- T2: Supply air
- T4: Extract air after heat exchanger
- T5: Condenser
- T6: Evaporator
- T10: Extract air

### Temperature sensors outside the unit

- T7: Supply air after heating element (accessory)

### Temperature sensors in the hot water tank

- T11: Top of tank
- T12: Bottom of tank

## Dimensional drawing

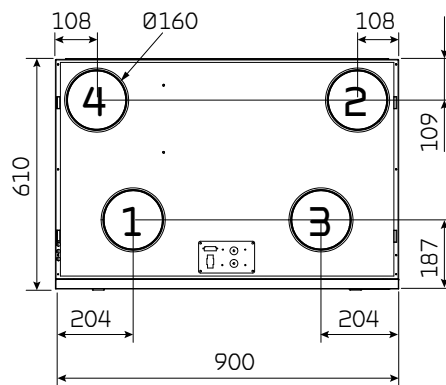
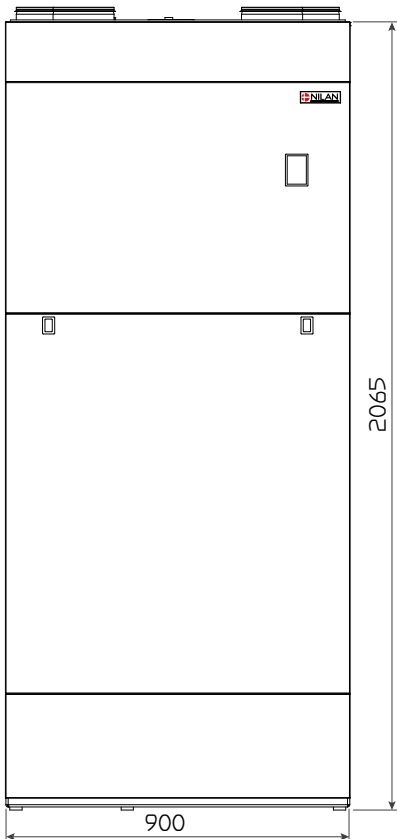

### Connections:

1. Outdoor air
2. Supply air
3. Extract air
4. Discharge air

Weight: 213 kg.

All listed measurements are in mm.

# Accessories

## Electrical pre-heating element for frost protection of the unit



If your ventilation unit is not a Polar version with an integral pre-heating element, we recommend that you purchase an external pre-heating element as frost protection of the ventilation unit.

During prolonged periods of frost, the high efficiency counterflow heat exchanger will ice up. To prevent ice formation, we recommend that you install an electrical pre-heating element.

The pre-heating element consumes limited energy and it ensures efficient heat recovery without periods of defrosting the counterflow heat exchanger. You thereby achieve an overall reduction in energy consumption.

## Electrical after-heating element for duct installation



Installing an after-heating element allows you to control the supply air temperature in the following cases:

- You want to use the ventilation air to heat the dwelling
- You want to control the supply air temperature to avoid potential cold draughts and coldness from the ventilation

The electrical after-heating element is for installation in the supply air duct. It would be an advantage to place it within the climate screen. It comes with the necessary sensors and connectors.

## CO<sub>2</sub> sensor



If you want to adjust the fan speed level in accordance with the level of use of the dwelling/building (amount of people), you can retrofit a CO<sub>2</sub> sensor. Nilan's CO<sub>2</sub> sensors calibrate automatically.

On the control panel, you select the CO<sub>2</sub> level you want. If this level is exceeded, ventilation will automatically increase.

## Expansion PCB



An expansion PCB extends the functions in the control system so you can control various accessories.

Under "Electrical connection accessories" you will be able to see which accessories require an expansion PCB.

## EM-box



If you want to run the cooker hood via the ventilation unit, in some cases there may be insufficient air for cooker hood extraction.

If you install an EM-box, you can regulate the extracted air when the cooker hood is in operation, so that less air is drawn from, for instance, the bathroom and the utility room. This will allow enough air for the cooker hood to extract sufficiently.

The EM-box is fitted with a metal filter that cleans the air in the cooker hood of grease particles efficiently. It thereby protects the ventilation unit.

## DTBU damper



If there is insufficient space for mounting an EM-box in the installation, you can achieve the same effect by controlling the extract air with a DTBU damper.

You then have to adjust the duct system yourself with a connection to the cooker hood.

## Extension cable HMI control panel



The control panel for the ventilation unit is connected up with a short wire so it can be installed close to the unit.

If you place the unit so the control panel is out of sight, for instance in a cupboard or in the loft, you can order a 15 m extension cable with plug. This allows you to place the control panel where it is visible to the user.

It is important that the control panel is visible so the user can see alarms when, for example, filters need replacing.

## Cover plate HMI user panel



It is possible to move the HMI control panel away from the unit and place it in a more visible place.

A cover plate can be ordered to cover the hole where the control panel was located.

## Safety group



By law, a safety group must be fitted for the cold water connection to the hot water tank.

Nilan offers a safety valve in brass with the following functions:

- Safety valve
- Check valve
- Stop valve
- Drain tab

## Safety group with scalding protection



The control has a software scald protection that ensures that the water in the hot water tank does not get too hot.

If you have a large cooling and / or heating need, it may be necessary to deactivate the software scald protection. The water in the hot water tank can be up to 90 ° C, which is why you need to install a safety group with scald protection.

If a solar panel is used to heat the domestic hot water via the supplementary coil in the hot water tank, a safety group with scald protection must be fitted.

## Flexible sound damper



To make it easy to service the unit in the future, we recommend that you fit a flexible connection between the unit and the duct system.

Nilan flexible sound damper absorbs sounds effectively from both the duct system and from roof stacks.

## Pollen filter



The ventilation unit comes, as standard, with a plate filter to protect the unit.

If the dwelling is used by anybody with, for instance, pollen allergies, you may benefit from purchasing a pollen filter. This should be placed in the outdoor air intake, which will reduce the pollen count in the dwelling.

## Trolley



A Nilan trolley makes it easy to transport the heavy units into the home, without having to carry out heavy lifting yourself with the risk of injury.

A set consists of two lifting carts that are fastened on each side of the unit while it is standing on the pallet. Using the two handles, lift the unit off the pallet and drive it to where it is to be used.

# Set-up

## Mounting

### Transport into the building

The ventilation unit is delivered fully assembled and wrapped on a pallet.

You can lift the unit from the pallet and transport it into the building by using a Nilan lifting dolly. You thereby avoid heavy lifting.



The unit is delivered from the factory fitted with 4 lifting straps, one in each corner.

This gives you the option of lifting the unit inside using a crane, which can be a considerable advantage, if the ground is not suitable for a lifting dolly.

When lifting the unit using the attached straps, these must be at an angle of 45° from vertical.

### Positioning the unit

Set up the unit so it is level on a firm surface free of vibrations. You need to have easy access to the unit for servicing and filter replacement.



#### ATTENTION

When positioning the unit, you should take into account future services and maintenance. We therefore recommend a minimum of 60 cm of free space in front of the unit.



#### ATTENTION

The unit must be level to ensure proper drainage from the condensate tray.



#### ATTENTION

If flashings are fitted above the unit, these must be easily removable.



Near the bottom on the sides and at the back of the unit, the metal has been punched out so you do not have to cut any holes yourself.

If you detach the metal angle from the base frame at the rear side of the unit, you will be able to push the unit closer to the wall and thereby hide connections for water.

# Electrical installation

## Safety



### ATTENTION

All work must be carried out by qualified persons and in compliance with existing legislation and regulations.



### ATTENTION

It is important that the power is off, if you do work to the electrical components of the unit.

It is important to check that wires are not damaged or squeezed during connection and use.

## Connections overview

A 230V connection is situated behind the large front door of the unit. At the top of the unit there is a connection for the control system via a USB cable, a connection for a LAN cable and an 8 pin plug. At the back of the metal plate you will find two terminal blocks for installation of external connections. Unscrew the four screws in the metal plate; then carefully pull up the plate.

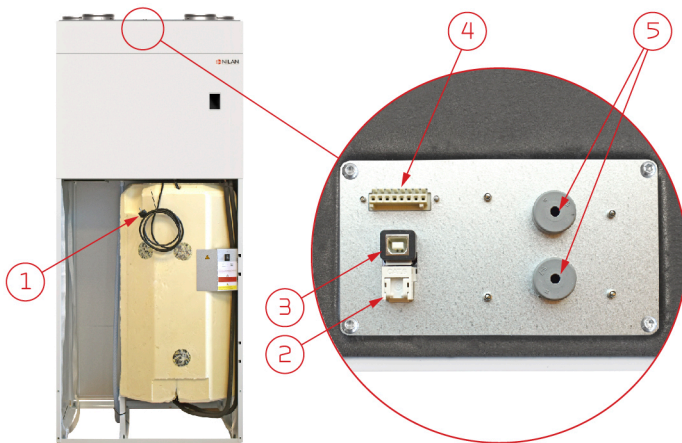

1. Connection of 230V via Schuko plug (remember electrical grounding)
2. Connection to the user's internet router via LAN cable
3. Connection of PC via USB cable
4. 8 pin plug for connection of any accessories
5. Cable glands for external electrical connections that have been installed in the terminal blocks at the back of the metal plate.

NB! The 8 pin plug has been packed with the instructions

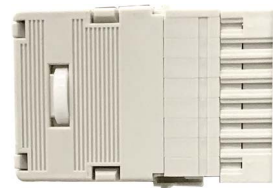

## Electrical connection unit

### Power supply



### CAUTION

The power supply is plugged into a 230V socket with a safety switch. It is important that the unit has earth connection.

The ventilation unit is supplied with an EU Schuko plug for 230V power supply.

This means that if you have not installed a schuko socket with side earth or pin earth, an Adapter schuko plug with pin earth must be used.

This Schuko adapter can be plugged into the ventilation unit's Schuko plug and then into a socket with earthing.



Schuko socket with side earth



Schuko socket with pin earth



Example of Adapter Schuko plug with pin earth

# Connecting a gateway

## Connecting to the internet

Using an RJ45 LAN cable, you connect the gateway to a router with an internet connection (the cable is not supplied by Nilan). The connection from the gateway is located at the top of the ventilation unit.

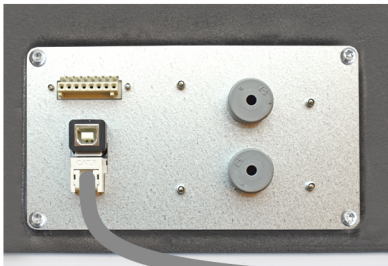

## Location on the unit



Once a connection to the router has been established, you will have a secure cloud connection. You can now communicate with the gateway via the Nilan User App. Additional information can be found in the user manual.

On Compact P2 (AIR/GEO) units, the gateway is installed in the unit. The ID number of the gateway is situated under the upper door at the front. You pull this outwards and lift it up.

The gateway arrives from the factory connected to power and to the Modbus connection of the unit.

# HMI Control panel

## Moving the control panel

The control panel is from the factory mounted in the front of the unit. It is important that the control panel is located in a visible place so that the user can follow the unit operation and become aware of any alarms. Therefore, it may be necessary to move the control panel to another location. It is also possible to follow the operation via the Nilan User App.

A cover plate can be purchased for mounting in the hole in the front of the unit where the control panel is located from the factory.

The panel is moved out of the unit and the wires are routed through the wire bushing and connected to the terminal block, as shown below.

Nilan offers a connection cable with RJ12 plugs of 15 m. It is also possible to customize a cable up to 50 m in length. A standard LAN cable is used for this.

### Mounting the RJ12 plug

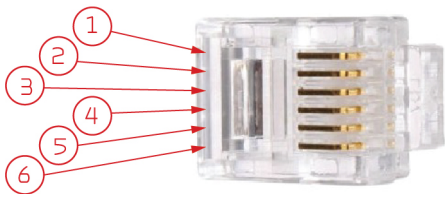

- Pin 3: Green (A2)
- Pin 4: Green/white (B2)
- Pin 5: Brown (12V)
- Pin 6: Brown/white (GND)

Use a RJ12 crimping tool



### Connection in the 7-pole terminal block

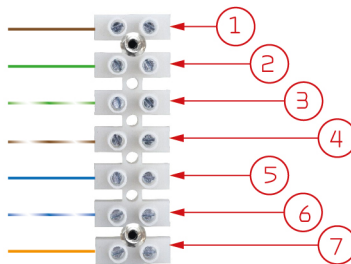
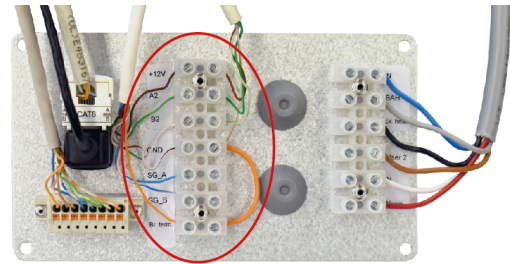

- Terminal 1: Brown (12V)
- Terminal 2: Green (A2)
- Terminal 3: Green/white (B2)
- Terminal 4: Brown/white (GND)

## Wall bracket

Mount the HMI panel on the wall using the integrated wall bracket.

The panel should be placed in a visible spot so it is possible to change settings and to monitor warnings or alarms regarding operation of the unit.



The wall bracket is located at the back of the panel. You can detach it by loosening the bracket at the bottom of the panel. You can then remove it.

Mount the wall bracket on the wall using 2 screws.

Click the RJ12 plug into place at the bottom of the HMI panel. The wire can run down along the wall, into the wall or through the groove at the back of the panel.

# Electrical connection accessories

## User selection 1

User selection 1 is connected via the 8-pin plug mounted on top of the unit.

The user selection functions are used to override normal operation. The input signal must come from a potential-free switch. When closed, the function is activated with the settings selected in the control panel under Service / User selection.

Some examples of the situations in which the user selection functions are used:

**Cooker hood** If you choose to run the cooker hood over the ventilation unit, the cooker hood sends a potential-free signal to the ventilation unit when it is switched on. When this happens, the ventilation unit increases the air volume to the set level, so that enough air is extracted through the hood.

**Fireplace/wood burning stove** Normally, the ventilation is balanced with a small negative pressure in the home, so that no moisture is forced into the building's construction. It is a disadvantage if you light up your fireplace / wood stove, as the smoke will then enter the home instead of out of the chimney.

When you switch on the fireplace/burning stove, you can activate the user function with a potential-free switch, which ensures that there is an overpressure in the home, so that the smoke smokes out of the chimney as it should.

**Extended operation** If the ventilation unit is used in an office or school where the ventilation is reduced outside the opening hours, it may be necessary to turn it up briefly if, for example when a meeting is held in the evening.

There you can then have a switch that is activated and the ventilation is increased e.g. for an hour before it then goes back into operation.

Connection via the 8-pin plug:

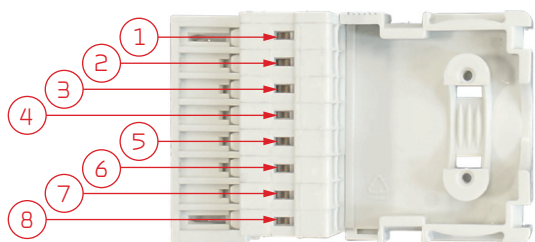

Pin 4: GND  
Pin 5: User selection 1

## Smart Grid

If you want to run Smart Grid, you must connect the Smart Grid modem to the ventilation unit as shown in the picture. The Smart Grid signal is connected to the circuit board in Compact P2, which also controls AIR and GEO if these have been connected up.

Smart Grid can be economically advantageous because it regulates the power consumption of the heat pump in line with the price of electricity as it fluctuates throughout the day. Smart Grid receives an external signal from the power supply company. This determines in which operating setting the unit is to run.

The connection is established via a terminal block that is located at the top of the unit. The connection to the terminal block is carried out at the back of the cover plate. You then run the wires through one of the cable glands. Connect the signal directly without resistors as these are already installed in the wire.

You program Smart Grid in the unit software under 'General settings'. See the options in the Software Instructions.

### Connection in 7-pin terminal block

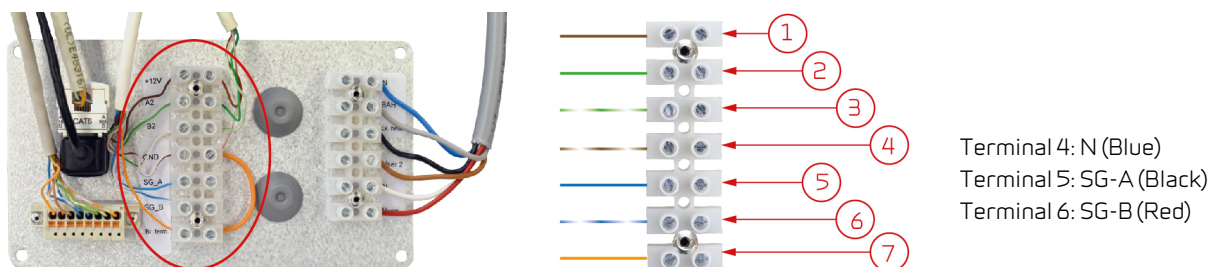

Smart Grid has four operating settings:

Operating setting	Status	Description
1. The heat pump is turned off	A: Closed B: Open	The power supply for the heat pump is disconnected, as many people are using electricity, which results in the price being high.
2. Normal operation	A: Open B: Open	The heat pump produces domestic hot water in accordance with the values that have been selected in the settings.
3. Low electricity price	A: Open B: Closed	During these periods when the price of electricity is low, it is possible to increase the production of domestic hot water.
4. Overcapacity of electricity	A: Closed B: Closed	There is an overcapacity of electricity, the price of electricity is low, and you therefore have to produce domestic hot water.

## External electrical pre-heating element

It is possible to purchase an external electrical pre-heating element for frost protection of the ventilation unit.

The electrical pre-heating element is mounted in the outdoor air duct before the unit with the necessary temperature sensor.

If it is desired to see the actual outdoor air temperature on the control panel, the temperature sensor T1 / T8 must be led out into the duct before the pre-heating element.

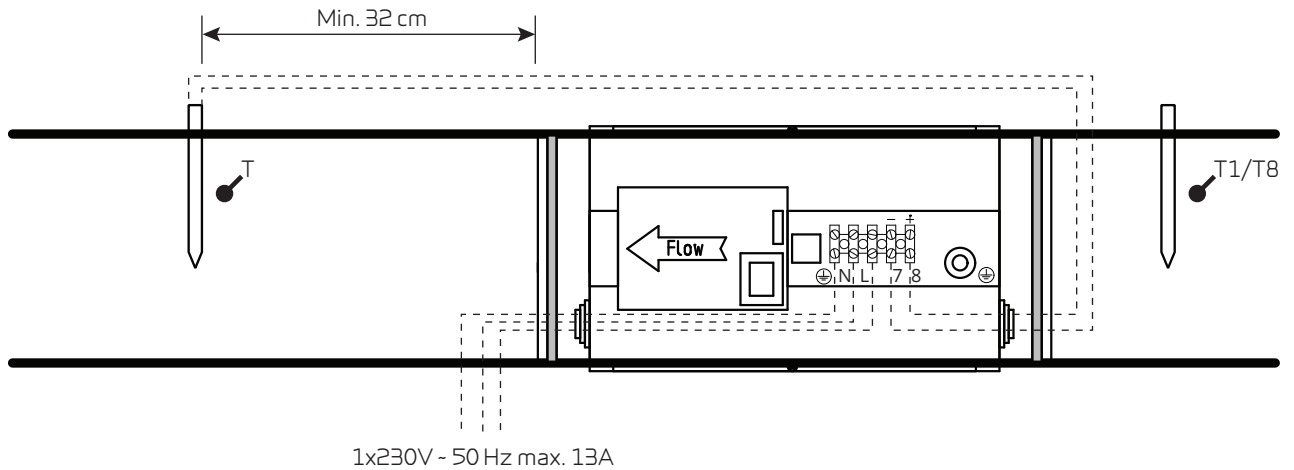

It is important that the sensor is placed at least 32 cm from the pre-heating element to achieve correct regulation.



The pre-heating element has a three-step safety system that prevents overheating.

1. An operating thermostat regulates the heating and ensures that the supply air temperature does not fall below  $-1\text{ }^{\circ}\text{C}$
2. Should the temperature exceed  $50\text{ }^{\circ}\text{C}$ , a max. thermostat switches off the pre-heating element. (If installed vertically with downward airflow, the pre-heating element switches off at  $70\text{ }^{\circ}\text{C}$ )
3. A safety thermostat switches off the pre-heating element if the temperature exceeds  $100\text{ }^{\circ}\text{C}$ . Then, you must reset it manually.

Minimum airflow at  $\text{Ø}160$ :  $110\text{m}^3/\text{h}$ .



### ATTENTION

The heating element must be insulated with a fire retardant insulation material. The cover of the Connection Box, however, must not be insulated.

### Dimensional drawing:

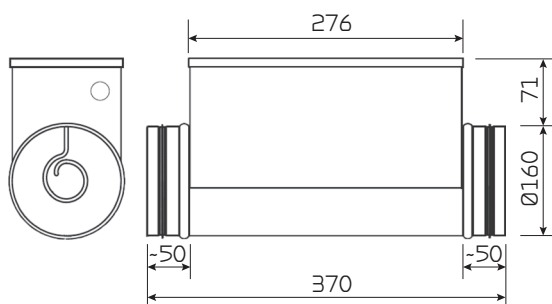

### Positioning options:

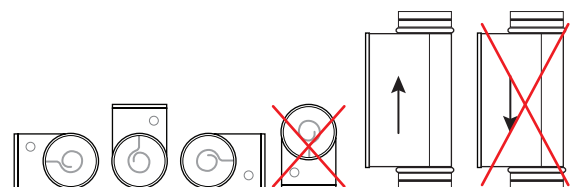

## Electrical after-heating element

If you want to control the supply air temperature, you will need an after-heating element.

You can purchase an electrical after-heating element for installation in the supply air duct. It comes with the required sensor and connection to the ventilation unit.

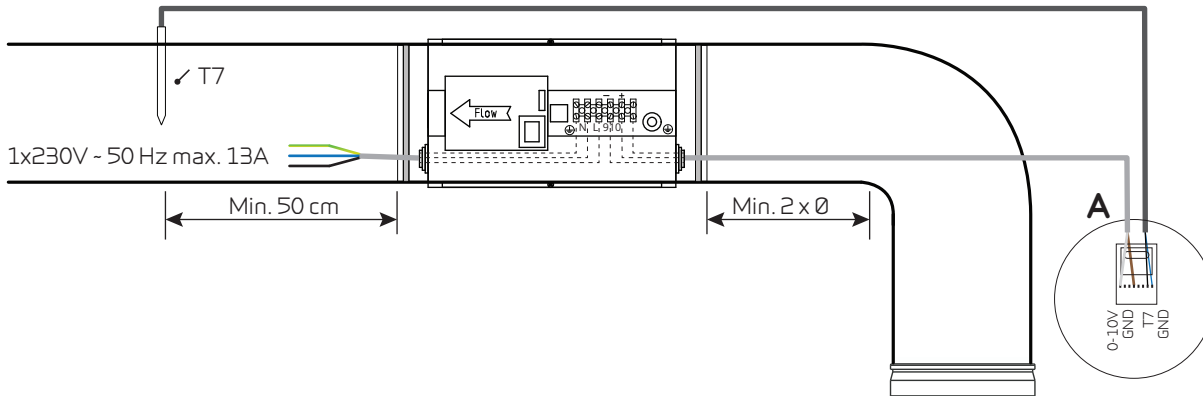

**A**

### Connection via the 8-pin plug:

Connect the electrical after-heating element in pin 1, 4, 7 and 8.



Run the wires along the duct and connect them to the ventilation unit via the 8-pin plug, which has been mounted at the top of the unit.



### ATTENTION

The heating element must be insulated with a fire retardant insulation material. The cover of the connection box, however, must not be insulated.

Dimensional drawing: Ø125/Ø160/Ø200

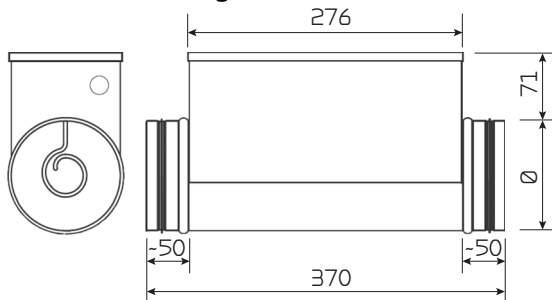

Positioning options:

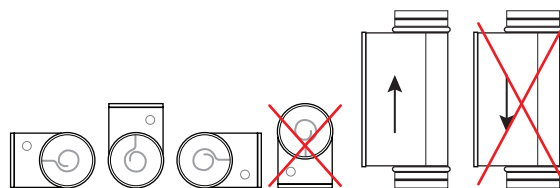

### ATTENTION

The after-heating element must be activated in the Software under "Service".

## Electrical after-heating element for mounting on top or on the side

If you want to control the supply air temperature, you will need an after-heating element.

You can purchase an electrical after-heating element for installation in the supply air duct. It comes with the required sensor and connection to the ventilation unit.

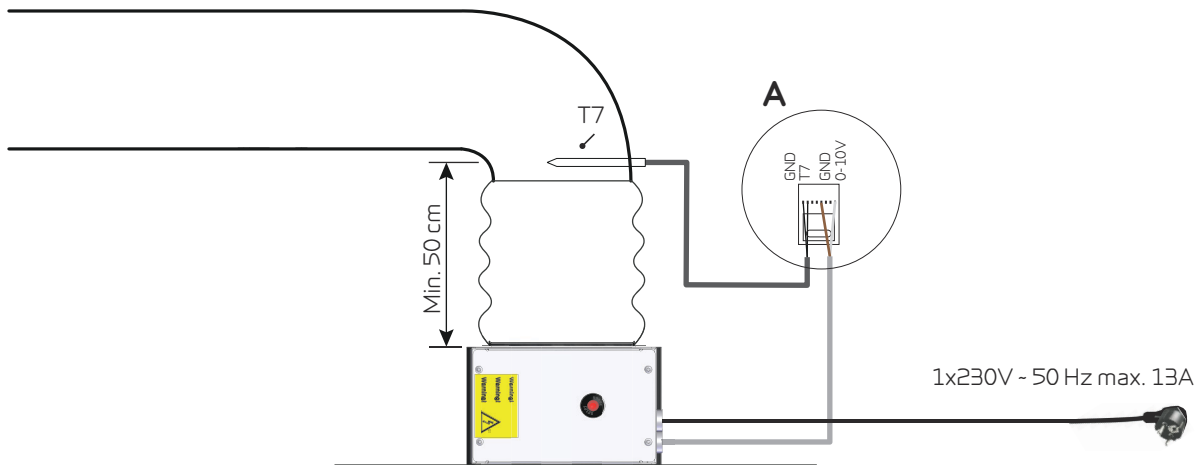

**A**

### Connection via the 8-pin plug:

Connect the electrical after-heating element in pin 1, 4, 7 and 8.



Run the wires along the duct and connect them to the ventilation unit via the 8-pin plug, which has been mounted at the top of the unit.



### ATTENTION

The heating element must be insulated with a fire retardant insulation material. The cover of the connection box, however, must not be insulated.



### ATTENTION

When installing the after-heating element, please ensure that you turn it so you can still easily open the electrical junction box.

### Dimensional drawing:

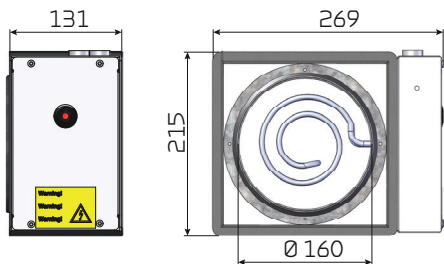

### Positioning options:

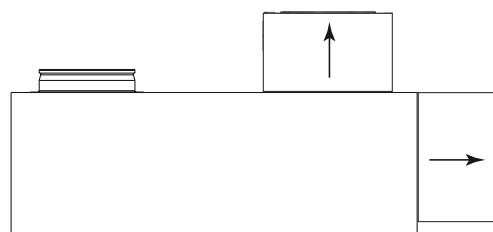

### ATTENTION

The after-heating element must be activated in the Software under "Service".

# Mounting an expansion PCB on the CTS602 circuit board

An expansion PCB allows you to expand the functions of the control system. It makes it possible for you to add accessories as shown on the following pages.

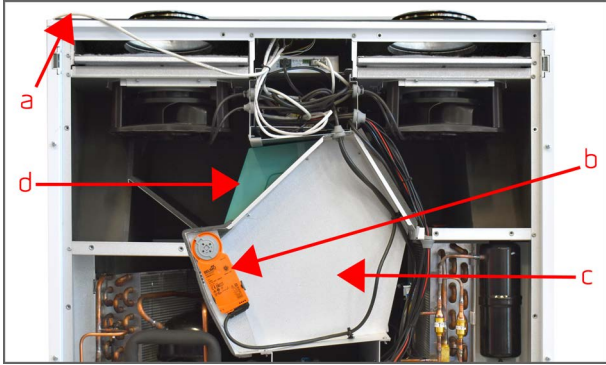

1. In order to access the circuit board on which the expansion PCB is to be installed, you will need to do the following:

- a: Detach the HMI panel on the front door from the wire so you can remove the front door. Then remove the rear plate.
- b: Detach the bypass motor with a click and loosen the wire from the bypass box.
- c: Unscrew the bypass box and remove it.
- d: Carefully pull out the counterflow heat exchanger.

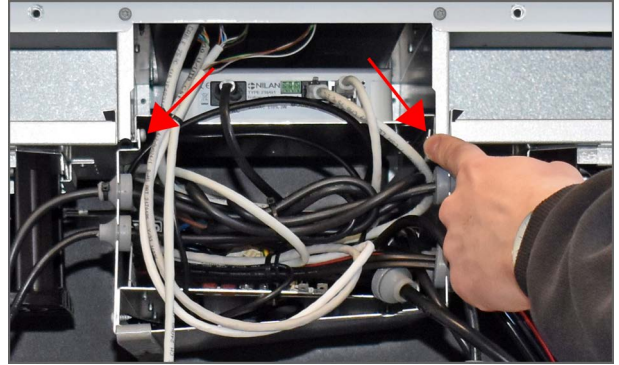

2. Remove the two screws on either side of the box for the control system.



3. Pull the control box forward in the slots, tip it downwards and let it hang in the profile.

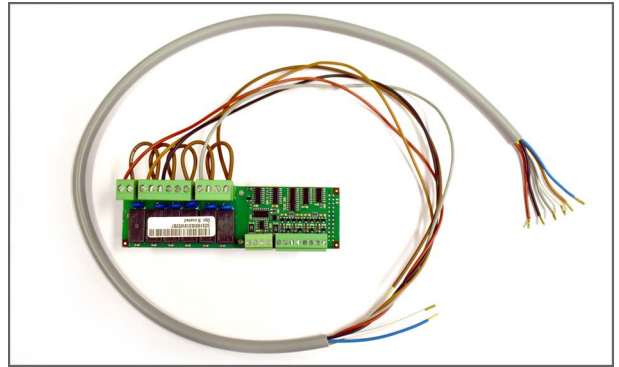

4. A cable has been mounted on the expansion PCB. Connect it up as shown on the wiring diagram.

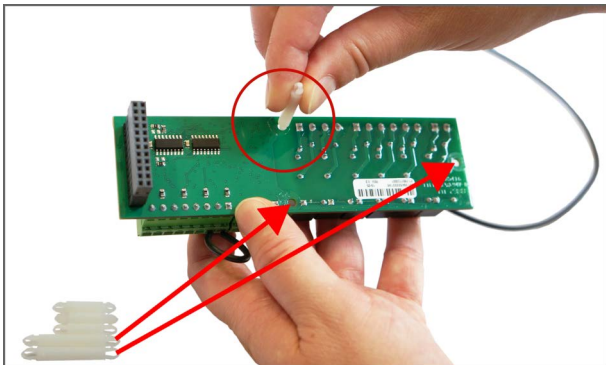

5. Mount the large PCB card supports, provided, in the 3 holes on the expansion PCB.

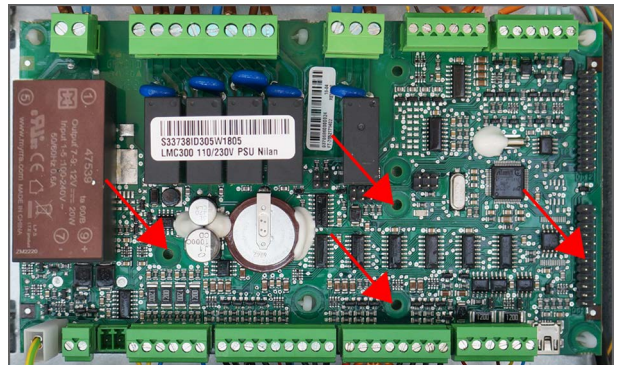

6. Connect the expansion PCB to CN9. Fit the PCB card supports in the holes made for this purpose on the CTS602 circuit board.

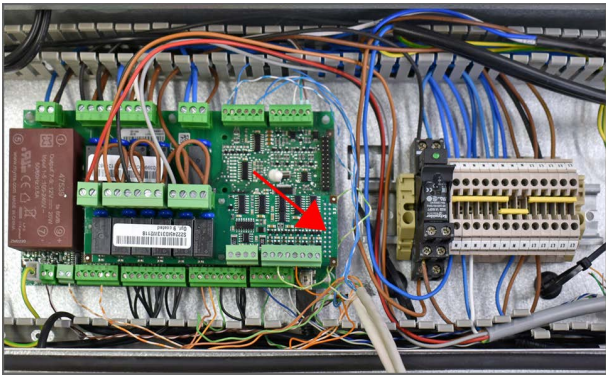

7. Mount the expansion PCB on the CTS602 circuit board. Mount the other wires on the expansion PCB in accordance with the wiring diagram.

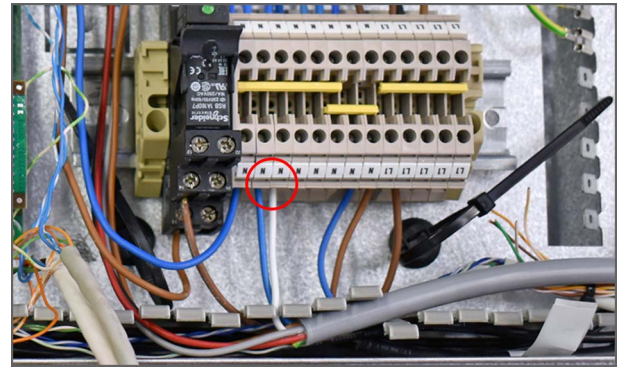

8. Connect up the white and the blue wires to the fuse as shown on the wiring diagram.

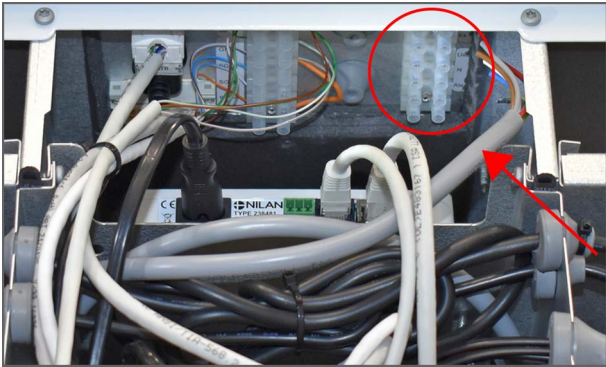

9. Run the cable in front of the gateway together with the other wires from the circuit board and mount them in the terminal block situated at the top of the Compact.

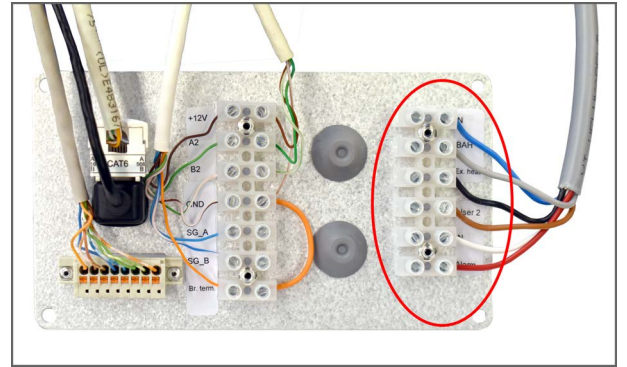

10a. Connect up the cable as depicted here. See also the wiring diagram provided. You can loosen the plate and access it from the top of the Compact. This makes installation easier.

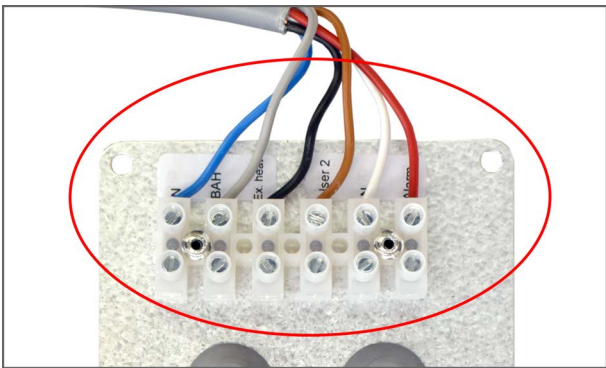

10b. Connect up the cable as depicted here. See also the wiring diagram provided. You can loosen the plate and access it from the top of the Compact. This makes installation easier.



**ATTENTION**

The expansion PCB and the connections must be installed by a certified electrician. The expansion PCB is an accessory to the CTS602 circuit board. Nilan does not supply external components.

## User selection 2

User selection 2 offers you the same options as User selection 1. In addition, you get the option of a relay output that can control e.g. a damper or whatever external function you may need to control.

The 8-pin plug and the terminal block are located at the top of the unit. You create the connection to the terminal block on the back of the cover plate. You then run the wires through one of the cable glands.

### Connection via the 8-pin plug:

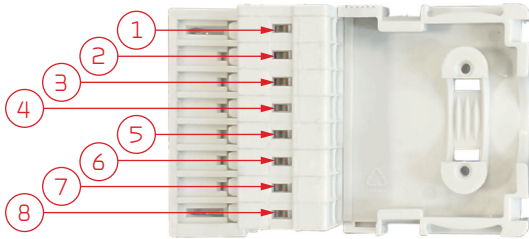

Pin 2: User selection 2

Pin 4: GND

### Connection in the 6-pin terminal block

Relay output that can control e.g. a damper or whatever external function you may need to control.

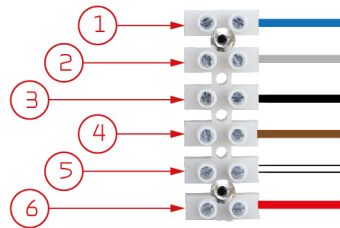
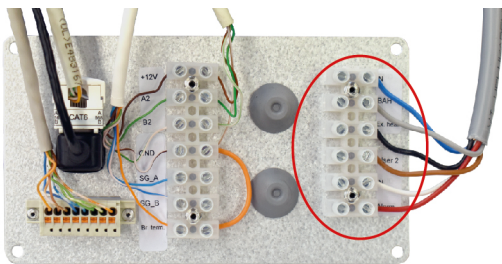

Terminal 4: User selection 2 (Output)  
Terminal 5: N (Output)

## Connection EHD damper

Leading outdoor air through a geothermal pipe in the ground makes good sense. During winter the outdoor air is heated by the ground, and during summer the outdoor air is cooled by the ground.

During autumn and spring, it is not always the most suitable solution to lead the outdoor air through a geothermal pipe. The outdoor air should instead be led in directly through a roof stack.

An integral function in the CTS602 control system measures whether it is best to lead the outdoor air through the geothermal pipe or in via the roof stack.

The control system measures the outdoor air temperature during a stabilization period in both the geothermal pipe and the roof stack. The measurements show which of the two options is most appropriate for leading in outdoor air. The CTS602 control system sets the EHD damper to use the best option and it continues operation for a fixed period of time. In the software this is called the retention time.

Connect the EHD damper in the 6-pin terminal block. Set it in the display.

### Connection in the 6-pin terminal block

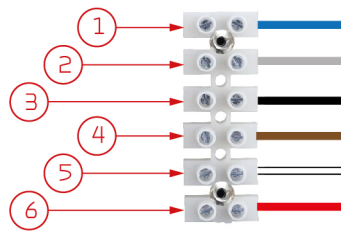
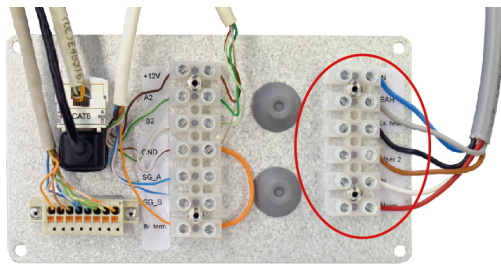

Terminal 2: EHD damper 230V

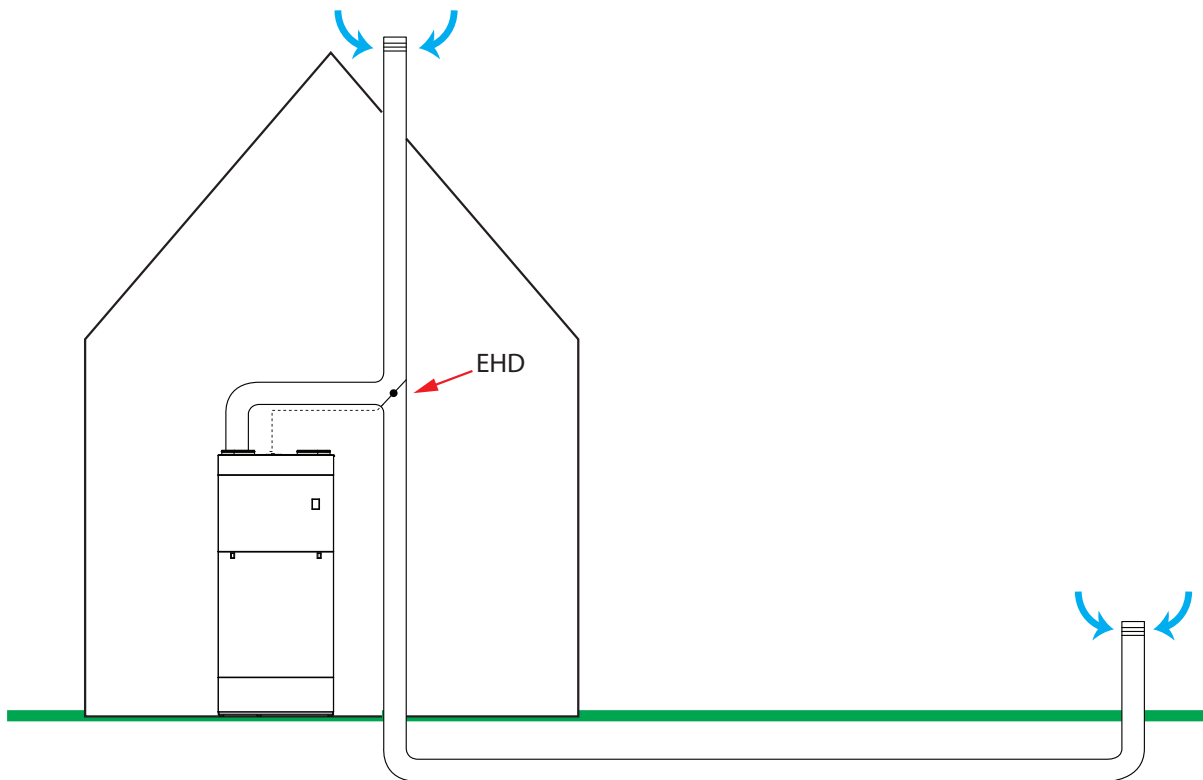

#### ATTENTION

Dampers, geothermal pipes and roof stacks are not supplied by Nilan.



#### ATTENTION

Please refer to the Software Instructions for activation and description of the EHD function.

# BAH Geothermal heating element

A geothermal pre-heating element has two functions:

1. During winter the function of the pre-heating element is to offer frost protection. It heats the outdoor air and prevents the unit from icing up
2. During summer it can cool the outdoor air so cool air can be led into the dwelling

Connect the circulation pump via the 6-pin terminal block that is located at the top of the unit. The connection to the terminal block is carried out at the back of the cover plate. You then run the wires through one of the cable glands.

Connect the pressure switch to the expansion PCB.

Select your settings in the control panel. Please read the Software Instructions to learn which settings you need to set.

## Connection in the 6-pin terminal block

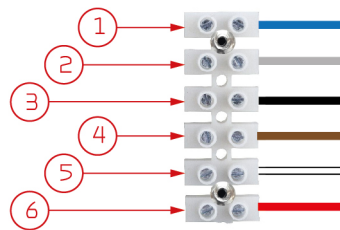
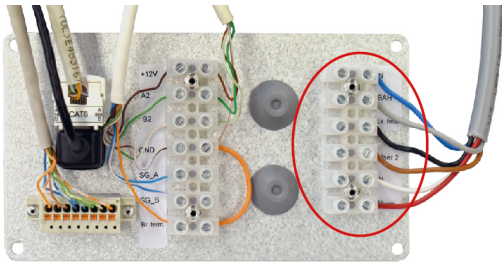

- Terminal 1: N
- Terminal 2: BAH Circulation pump

## Optionsprint

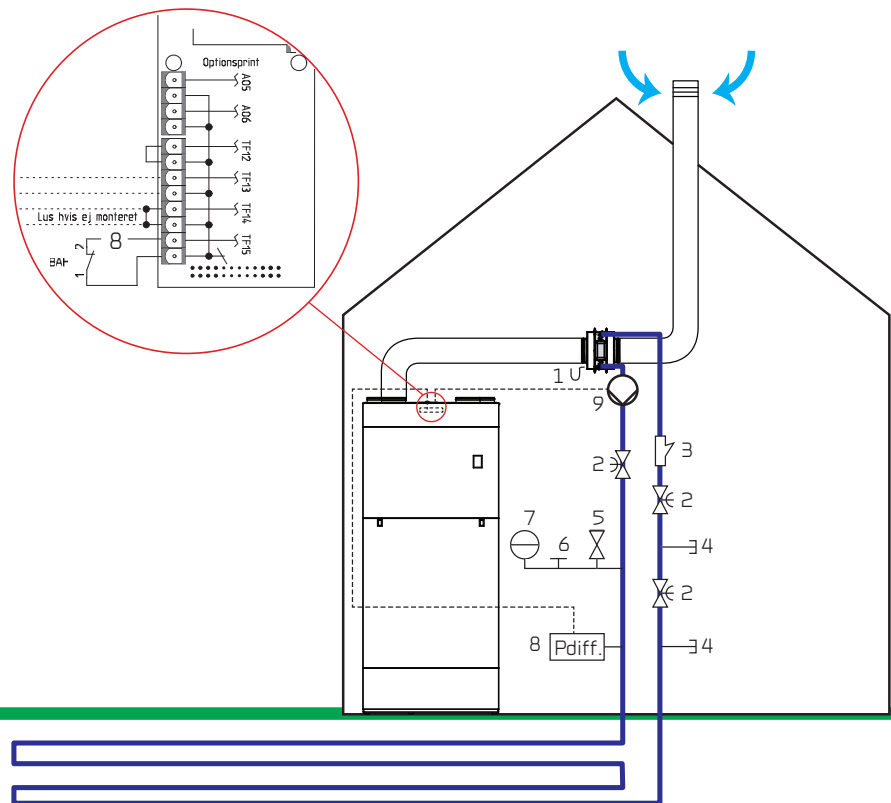

1. Condensate drain
2. Shut-off valves
3. Particle filter
4. Fill and drain valves
5. Safety valve
6. Bleed screw
7. Expansion tank
8. Pressure switch
9. Circulation pump



### ATTENTION

Circulation pump, heating element and brine circuit are not supplied by Nilan.

## EM-box (damper option)



If it is desired to run the cooker hood over the ventilation system, it may in some cases be difficult to get enough air for the cooker hood.

With an EM box installed and when the cooker hood is in operation, you can regulate the extraction so that less air is extracted out of the other rooms, e.g. bathroom and utility room so that there is enough air for the cooker hood to extract sufficiently.

The EM box is equipped with a metal filter that effectively cleans the cooker hood air of grease particles, as extra protection for the ventilation unit.

### The system works as follows:

When the cooker hood is switched on, User selection 2 is activated. The ventilation unit increases the ventilation and at the same time sends an output signal to the EM box that it must close the damper for extract air from the other rooms. However, the damper does not close completely in, there will still be extraction from the other rooms, just reduced.

When balancing, the small stop blocks on the damper must be set so that the basic ventilation is maintained from the other rooms.

The EM box is connected to the 8-pin plug. Pin 2: User Selection 2 and Pin 4: GND. The relay output is connected in the 6-pin terminal block. Terminal 4: User selection 2 (Output) and Terminal 5: N (Output) as shown in User selection 2.

### Dimensional drawing:

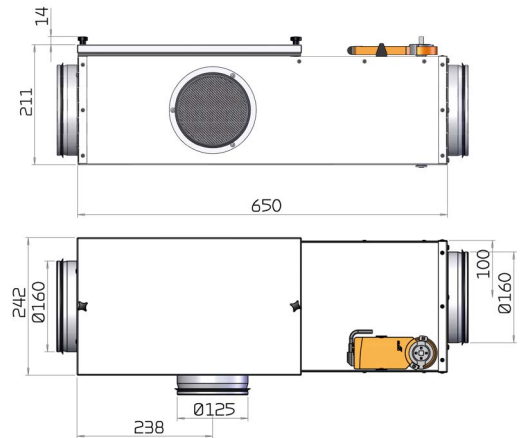

## DTBU (damper option)



If it is desired to run the cooker hood over the ventilation system, it may in some cases be difficult to get enough air for the cooker hood.

To solve that challenge, an EM-box solution can be used. However, if there is not enough space in the installation for an EM box, you can alternatively connect a DTBU damper in the duct system, which has the same function, except that it does not have a built-in dirt filter. However, a filter box with a steel filter can be purchased, which can be mounted in the duct system in a suitable place.

The DTBU damper regulates the extract air so that less air is extracted out of the other rooms, e.g. bathroom and utility room so that there is enough air for the cooker hood to extract sufficiently.

### The system works as follows:

When the cooker hood is switched on, User selection 2 is activated. The ventilation unit increases the ventilation and at the same time sends an output signal to the DTBU damper that it must close the damper for extract air from the other rooms. However, the damper does not close completely in, there will still be extraction from the other rooms, just reduced.

When balancing, the small stop blocks on the damper must be set so that the basic ventilation is maintained from the other rooms.

The DTBU damper is connected to the 8-pin plug. Pin 2: User Selection 2 and Pin 4: GND. The relay output is connected in the 6-pin terminal block. Terminal 4: User selection 2 (Output) and Terminal 5: N (Output) as shown in User selection 2.

## Fire thermostat / external fire automation system

The ventilation unit can be connected up to an external fire thermostat that will stop the ventilation unit in the event of fire. The same input port can be used for connecting an external fire automation system.

The control system registers any disruption of the input signal as fire, and stops. It will only restart once connection to the fire thermostat has been reestablished or the external fire automation system starts signalling again. This must be done manually via the control panel.

When you connect up an external fire automation system, you will need the ventilation unit to restart automatically. You can set for this to happen on the control panel. Please consult the software instructions for further information.

The connection is created via a terminal block that is located at the top of the unit. The connection to the terminal block is carried out at the back of the cover plate. You then run the wires through one of the cable glands.

### Connection in the 7-pin terminal block

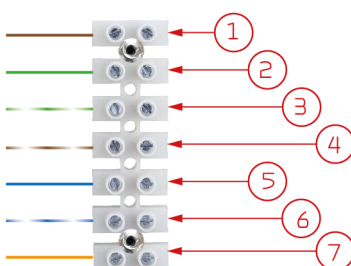
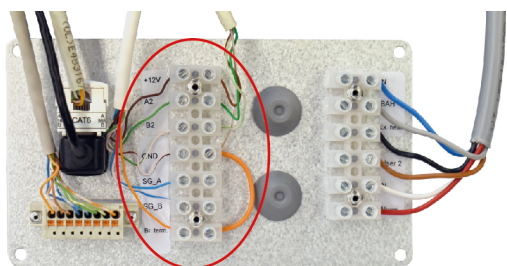

Terminal 4: GND

Terminal 7: Fire thermostat / external fire automation system

## Joint alarm

It may be difficult to notice alarms if the unit is located in a place where access is difficult or infrequent, and if the control panel is located in the same place.

An external alarm indicator in the form of an electric bulb or an acoustic signal can be connected to the ventilation unit and announce when an alarm occurs. This could, for example, be when filters need replacing.

The connection is created via a terminal block that is located at the top of the unit. The connection to the terminal block is carried out at the back of the cover plate. You then run the wires through one of the cable glands.

### Connection in the 6-pin terminal block

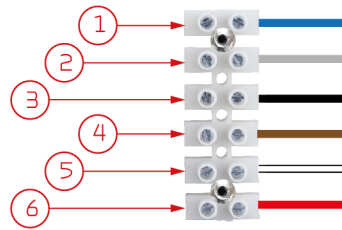
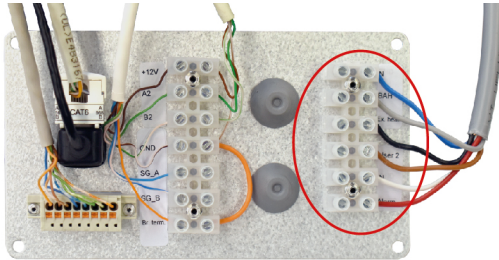

Terminal 5: N  
Terminal 6: Joint alarm

## External heat supply

The unit can control an external heat supply such as electric radiators or an underfloor heating system. This function is used when the unit helps heat the dwelling via a heat pump and/or an after-heating element.

The room temperature is monitored by the control system of the unit. It will only release the external heat supply if the required room temperature in the dwelling/building cannot be reached by means of the unit alone.

The connection is created via a terminal block that is located at the top of the unit. You create the connection to the terminal block on the back of the cover plate. You then run the wires through one of the cable glands.

Select your settings in the control panel. Read the software manual to learn which settings you need to set.

### Connection in 6-pin terminal block

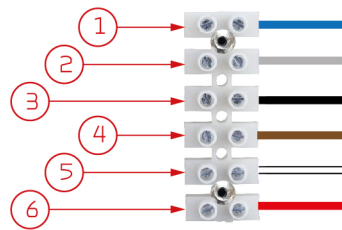
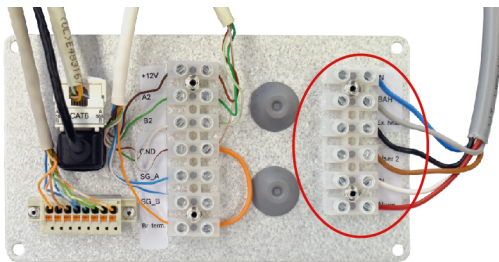

Terminal 3: External heat supply  
Terminal 5: N

# Plumbing installation

## Condensate drain

### Important information

Compact P2 is supplied with a reinforced 20 mm condensate drain tube with an integral water trap.



#### ATTENTION

Run the condensate drain tube to the nearest drain, allowing an even fall of at least 1 cm per m.

The overflow from the safety valve for domestic cold water must likewise be led to a clearly visible drain.



#### ATTENTION

If the unit is set up outside the climate screen, it is important to protect the condensate drain from frost.

Frost protection of the unit is the installer's responsibility.

Once installed, check the function of the water trap in the following way (the unit must be connected up to the duct system):

Fill the condensate tray with water, close the unit door and start the ventilation unit at the highest fan speed level. Allow it to run for several minutes. Open the door and check that the water has drained from the condensate tray.



The loop on the tube from the condensate drain functions as a water trap. It has been fastened with tie strips that must not be cut or removed under any circumstances.

# Hot water tank

## Connection overview

Compact P2 front

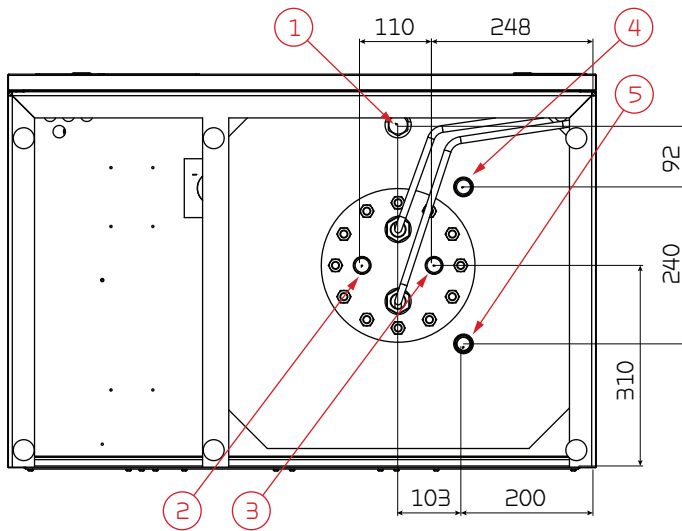

### Connections:

1. Connection for 3/4" circulation pipe
2. Hot water outlet 3/4"
3. Cold water intake 3/4"
4. Return supplementary coil 3/4"
5. Supply supplementary coil 3/4"

All listed measurements are in mm.

Supplementary coil is only standard on Compact P2 SOL models.

The coil is located in the bottom, and has an external diameter of 22 mm and is 8,500 mm long, equivalent to 0.6 m<sup>2</sup>.

## Plumbing connection



### ATTENTION

All work must be performed by qualified personnel and in accordance with relevant legislation and regulations.

Nilan's hot water tanks are double-enamelled, ensuring long life. The efficient foam insulation protects against unnecessary heat loss.

All connection nozzles for water have 3/4" thread and are located in the tank bottom.

The tank is also fitted with an electronically-monitored sacrificial anode that automatically displays a warning on the display when it needs changing.



### CAUTION

Changing the anode when notified on the display is important. Failure to do so can cancel the guarantee on the hot water tank.

The tank is fitted with supplemental electric heating deactivated by default and activated via the control panel if required.



### ATTENTION

The supplemental electric heating must not be activated before the water tank is full of water.

## Requirements to quality of water

The hot water tank in the Nilan units is made of steel, which has been given a double enamelling, to ensure an extra long service life. In addition, the tank is equipped with a sacrificial anode as extra protection. It is important that the sacrificial anode is replaced regularly.

Most units are equipped with an electronic monitoring sacrificial anode, which gives an alarm on the user panel when it is time to replace it.

In order for the sacrificial anode to function and protect the tank, it is required that the water quality complies with the following:

- Electrical conductivity (EC): Between 30 mS/m and 150 mS/m (millisiemens pr. m) @ 25 °C
- Chloride must be below 250 mg/L @ 65 °C

If the above criteria are not met, the sacrificial anode will not work as intended, after which the tank will be corroded.

## Hot water circulation

Hot water circulation can be established by fitting a non-return valve and a circulation pump for domestic water to the tank's circulation connector.

If hot water circulation is not established, the connector must remain closed with the factory-mounted shut-off plug.



### ATTENTION

Hot water circulation can lead to a significant heat loss in the pipes, diverting a good proportion of the heat pump's output. To avoid this, circulation pipes and the hot water loop must be insulated with at least 30 mm mineral wool.

It is advisable to set a timer so that the circulation pump is not running constantly.

## Supplementary coil

All units ordered as a SOL models have integral supplementary coil, see connections list.

The supplemental coil is intended for solar heating systems, though it can also be connected to other heat sources, e.g. a heat pump.



### ATTENTION

If a solar collector or other heat source is connected to the supplementary coil, it is recommended to install a scald protection on the hot water outlet.

## Softened water

If it is wished to soften water with salt in a Nilan hot water tank, the following must be observed:

- The conductivity must be between 30 mS/m og 150 mS/m (millisiemens per m)
- The chloride content must be under 250 mg/L

If the above criteria are exceeded, the anode current will be too high, the anode will break down too quickly and the water will begin to smell bad.



### CAUTION

De-mineralised water (double ion exchange) must not be used, as the tank will quickly corrode. De-mineralised is also referred to as desalinated and de-ionised water.

# Plumbing connections accessories

## Safety group



### CAUTION

Safety group must be installed in connection with hot water tanks.

When water is heated to 60 °C, it expands by 2%. A pressured tank could burst without a safety valve keeping excess water out. The safety valve should therefore drip during warming up.

### Installation:

a. The double nut is attached to the water heater's cold water pipe so that the arrows are pointing in towards the water heater (in the direction of the flow). The joint with the water heater is sealed using a threaded washer.

b. The joint between the double nut and the unit is sealed using fibre packing.

c. The rubber ring seal (the O-ring) is fitted to the unit so that it can function as a seal between the safety valve and the unit in such a way that the valve is locked.

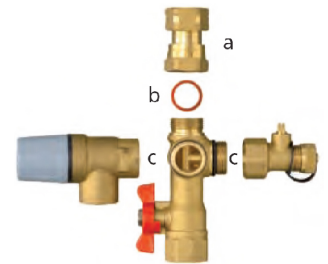

The end of the overflow pipe must be visible, and it must be able to run out safely via the drain.



### ATTENTION

Water expands as it heats up, therefore the safety valve will drip.



### ATTENTION

The installer is responsible to instruct the consumer about the location and function of the safety valve, as well as that the safety group at least twice a year should be tested to avoid overgrowth.

## Safety group with anti-scald protection

In the control, a temperature limit for the domestic hot water of 65°C is set as standard. This setting prevents scalding of the users when the hot water tap is opened.

When the unit is in cooling mode, the energy is deposited in the hot domestic water tank instead of leading it out of the house. This also means that if the hot water temperature exceeds 65°C, the unit stops cooling the supply air. If there is a larger need for cooling, the temperature limit can be raised to 80°C, but then a scalding fuse must be fitted under the hot water tank, which prevents users from scalding when they open the hot water tap.

The scald protection mixes the hot water with cold water so that the temperature is lowered and scalding is avoided. This extended the period during which Compact can cool.



### CAUTION

If a solar panel is connected to the hot water tank, an anti-scald device must be mounted.

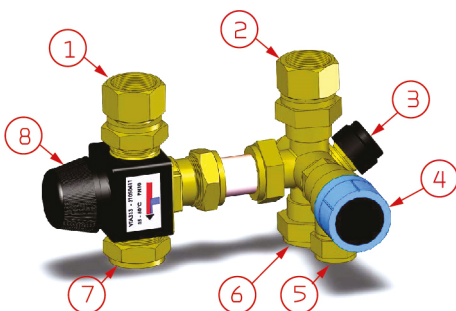

1. Hot water from the hot water tank
2. Cold water to the hot water tank
3. Stop tap cold water
4. Pressure relief valve
5. The overflows from the safety valve are led to a prominent drain
6. Cold water supply
7. Domestic hot water for the dwelling
8. Mixing valve for domestic hot water for the dwelling (can be set between 35 - 60 °C)

# Ventilation installation

## Duct system

### Legislation



#### ATTENTION

All work must be carried out by qualified persons and in compliance with existing legislation and regulations.

## Ducts

There are two systems you can use to lead air through the dwelling.

### Spiral ducts

Spiral ducts are made from metal and are cut to size using an angle grinder. They are then connected using ducting bends and manifolds and are fitted in accordance with the blueprint. The ducts are typically placed on the tie beams where they are fixed with perforated band, or they are suspended using suspension band. Avoid unnecessary bending of the ducts.

To prevent sound transmission from room to room, you should install a silencer for each room.

The ducts must be insulated to prevent heat loss and condensation. In some cases this can be avoided if the ducts are run through the standard insulation or inside the climate screen.

### NilAIR tubes

NilAIR tubes constitute a flexible system that is easy to install. You can easily cut the tubes to size with a Stanley knife and then situate them in accordance with the blueprint without having to use bends and manifolds. You install a manifold box after the unit and run the tubes from the box out to the individual rooms.

When using NilAIR tubes, you do not have to install silencers for each room. The sound-damping effect of the tubes ensures that sounds and noise will not be transmitted from room to room.

If you install the tubes outside the climate screen, you must insulate them to avoid heat loss and condensation. This is simpler than using spiral ducts as NilAIR tubes are easily led through the standard insulation.

NilAIR tubes are more flexible than spiral ducts and you can therefore run the tubes in places that are unsuitable for ordinary spiral ducts.



#### ATTENTION

If the unit's cooling function is activated, it is recommended to condensate-insulate the supply air ducts and NilAIR boxes.

## Ventilation unit

Nilan recommends installation of flexible connections between the ventilation unit and the duct system.

This is to avoid vibrations from the unit being transmitted to the duct system. It will also make it easier to move the unit, which may be necessary during future services of the unit.

Nilan can supply Soundflex tubes that you can use as flexible connections between the ventilation unit and the duct system. They will also reduce sounds from the system considerably.

The Soundflex tubes are insulated against condensation. It may, however, be necessary with further insulation in order to comply with local requirements with regards to insulation of duct systems.

## Extract air

Install the extract air valves in high-humidity rooms and place them strategically where they can extract humid and vitiated air from the dwelling/building most efficiently.

High-humidity rooms are, for example:

- Bathroom
- Lavatory
- Kitchen
- Utility room

## Supply air

Install supply air valves in living areas. Place them strategically so they cause minimum discomfort. It is, for instance, not recommended that you install supply air valves in areas where people are inactive, as the supply air may be experienced as draughty.

Living areas may be, for example:

- Living room
- Family room
- Bedroom
- Study

## Roof terminals

The position and design of air intake and air discharge should limit pressure oscillations in the ventilation unit caused by wind. Their position should also prevent birds and other animals from getting in. Finally, the position and design should ensure that air intake and the connected duct system are kept free of plants and foreign objects.

You must place the air intake so that the risk of a short-circuit from the discharge air is minimised, and with attention to the prevailing wind direction.

The air intake should be placed at least 50 cm above the roof surface. On black, flat roofs the distance from the roof to the underside of the intake should be at least 1 m. This will ensure that warm air is not drawn into the building during summer. Air intakes should be placed on the northern or eastern sides of pitched roofs.

You should also install a silencer between the unit and the roof stacks to prevent noise disturbance to your surroundings.

## Installation example

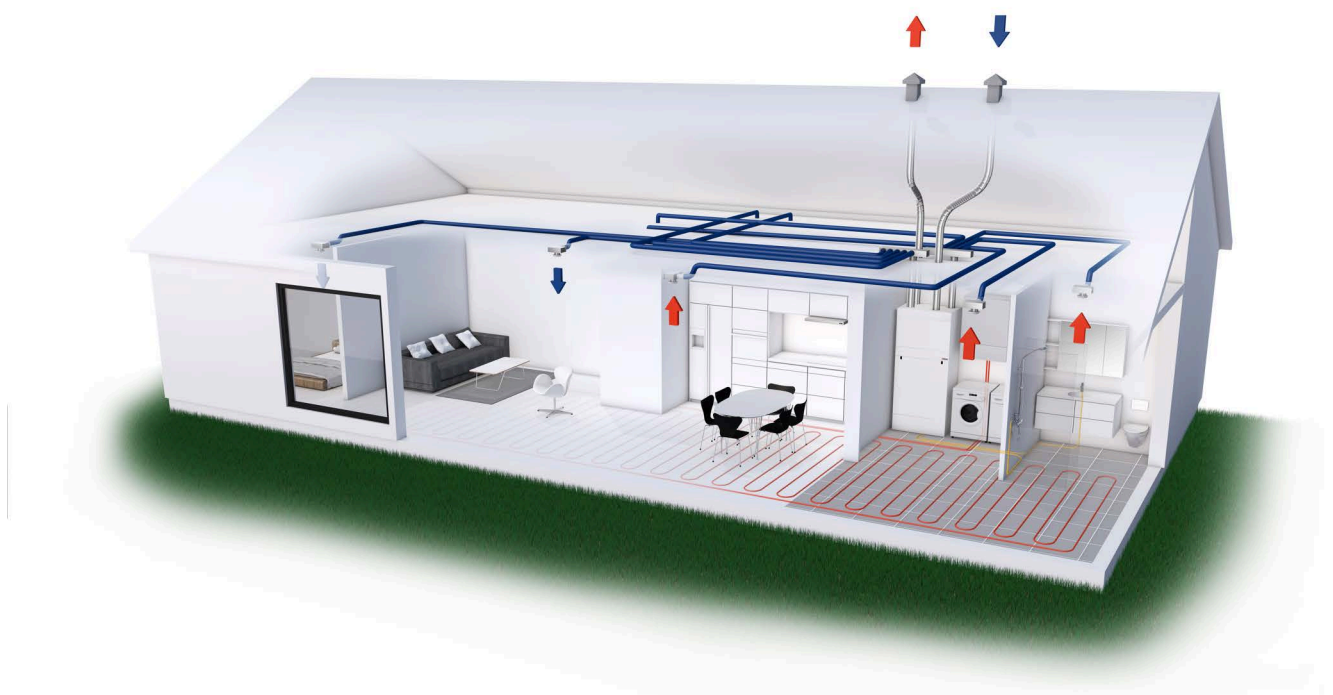

# Balancing

## Important information



### ATTENTION

To ensure the ventilation system operates optimally, it is important that it is balanced correctly. We recommend that experts do this.

It is important to measure the total supply air and the total extract air. The system must have a minimum vacuum, which means it draw out more air than it blows in. This will prevent dampness from being forced into the constructions of the building.

# Troubleshooting

## Emergency mode

### Emergency mode domestic hot water

If an error occurs in the control system or components in the Compact P2, and the unit therefore stops, it will not be able to produce domestic hot water.

If the installer is not able to come right away or the error happens outside the opening hours, and you therefore cannot contact the installer, there is a possibility to get hot water by setting the unit into emergency mode.



The button for emergency mode is located behind the large door.

The emergency mode has three settings:

#### I - Auto:

The supplemental electric heating is controlled by the unit control system (standard setting)

#### 0 - Off:

The supplemental electric heating is turned off, and cannot be turned on via the unit control system

#### II - Manuel:

The supplemental electric heating is turned on, and cannot be turned off via the unit control system (do not turn it on if there is no water in the tank)



#### CAUTION

In manual emergency mode, the water temperature can reach 75 °C, which can cause scalding, if you are not careful when switching on the hot water.

# Domestic hot water

## Errors and solutions domestic hot water

Problem	Possible cause	Solution
The unit produces insufficient domestic hot water.	The filters may be blocked so that insufficient air is reaching the unit. This can occur if the filters are not changed frequently. This can occur if the unit has been operated during the building process and the filters are filled with dust and dirt.	Change the filters and, if necessary, change the filter change period to a shorter Interval.







Nilan A/S  
Nilanvej 2  
8722 Hedensted  
Danmark  
Tlf. +45 76 75 25 00  
nilan@nilan.dk  
www.nilan.dk

Nilan A/S disclaims all liability for potential errors and omissions in printed instructions - or for loss or damages arising from published materials, whether these are due to errors or in expediency in the publications or they have other causes. Without prior notice Nilan A/S reserves the right to make changes to the products and instructions. All trademarks belong to Nilan A/S. All rights reserved.